

**auma**<sup>®</sup>

# Part-turn gearboxes

GHE 05.1 – GHE 12.1



Certificate Registration No.  
12 100/104 4269

Operation instructions

**Scope of these instructions:** These operation instructions are valid for AUMA part-turn gearboxes GHE 05.1 – GHE 12.1.

## Table of contents

	<b>Page</b>
<b>1. Safety instructions</b>	<b>3</b>
1.1 Range of application	3
1.2 Maintenance	3
1.3 Warnings and notes	3
<b>2. Short description</b>	<b>3</b>
<b>3. Technical data</b>	<b>4</b>
<b>4. Transport, storage and packaging</b>	<b>6</b>
4.1 Transport	6
4.2 Storage	6
4.3 Packaging	6
<b>5. Mounting to valve</b>	<b>7</b>
<b>6. Checking of the mechanical end positions CLOSED and OPEN</b>	<b>8</b>
6.1 End position CLOSED	8
6.2 End position OPEN	8
<b>7. Maintenance</b>	<b>9</b>
<b>Index</b>	<b>11</b>
<b>Addresses of AUMA offices and representatives</b>	<b>12</b>

## 1. Safety instructions

### 1.1 Range of application

AUMA part-turn gearboxes GHE 05.1 – GHE 12.1 are used for the operation of valves (e.g. butterfly valves and ball valves).

For other applications, please consult us. The manufacturer is not liable for any possible damage resulting from use in other than the designated applications. Such risk lies entirely with the user.

Observance of these operation instructions is considered as part of the actuator's designated use.

### 1.2 Maintenance

The maintenance instructions (refer to page 9) must be observed, otherwise a safe operation of the part-turn gearbox is no longer guaranteed.

### 1.3 Warnings and notes

Non-observance of the warnings and notes may lead to serious injuries or damage. Qualified personnel must be thoroughly familiar with all warnings and notes in these operation instructions.

Correct transport, proper storage, mounting and installation, as well as careful commissioning are essential to ensure a trouble-free and safe operation.

The following references draw special attention to safety-relevant procedures in these operation instructions. Each is marked by the appropriate pictograph.



**This pictograph means: Note!**

“Note” marks activities or procedures which have major influence on the correct operation. Non-observance of these notes may lead to consequential damage.



**This pictograph means: Warning!**

“Warning” marks activities or procedures which, if not carried out correctly, can affect the safety of persons or material.

## 2. Short description

AUMA part-turn gearboxes type GHE 05.1 – GHE 12.1 for manual operation are available for swing angles up to 98°. Positive stop in both end positions by travelling nut. Version for swing angle > 98°, without end stops.

The patented ellipto-centric gearing makes it possible to realise high reduction ratios in one stage. The gearboxes are self-locking. Input and output drive are arranged coaxially. Turning the handwheel clockwise results in the same direction of rotation at the output drive (when looking onto the valve shaft).

### 3. Technical data

**Table 1: Part-turn gearboxes GHE 05.1 – GHE 12.1**

Type	Output torque max. Nm	Reduction ratio	Turns at the input shaft for 90°	Factor <sup>1)</sup> approx.	Input torques <sup>2)</sup> approx. Nm	Valve attachment		Valve shaft			Weight <sup>4)</sup> approx. kg
						Housing GGG	Option Housing BZ	Shaft Ø max. mm	Square max. mm	Two-flat max. mm	
<b>GHE 05.1</b>	125	80:1	20	25	5	F07 F10 <sup>3)</sup>	F 07	20	17	16	2.5
<b>GHE 07.1</b>	250	80:1	20	25	10	F07 F10 <sup>3)</sup>	F 07	25.4	22	22	4.0
<b>GHE 10.1</b>	500	80:1	20	25	20	F10 F12 <sup>3)</sup>	F 10	38	30	27	7.5
<b>GHE 12.1</b>	1000	80:1	20	25	40	F12 F14 <sup>3)</sup>	F 12	50	36	41	13

#### Application

Part-turn gearboxes      Manual operation (e.g. butterfly valves and ball valves)

#### Features and functions

Version	Clockwise rotation RR
Housing material	Standard: GGG (spheroidal cast iron) Option: Bronze
Self-locking	yes
Swing angle	Standard: 90° (adjustable from 82° to 98°) Option: multi-turn version, without end stops
Mechanical position indicator	Continuous position indicator
Operating element	Standard: Handwheel made of polyamide Option: Handwheel with ball handle Operating elements according to VG 85 081 made of bronze in version A or with ball in version B
Valve attachment	Standard: according to EN ISO 521 1, integrated into the housing Option <sup>3)</sup> : with adapter flange
Splined coupling for connection to the valve shaft	Part-turn gearbox can be repositioned 4 x 90° on coupling Standard: Coupling without bore Option: Machined coupling with bore and keyway, square bore or bore with two-flats
Coupling material	Option: Version made of bronze

#### Service conditions

Enclosure protection according to EN 60 529	Standard: IP 67 <sup>5)</sup> Options: IP 68 <sup>6)</sup>
Corrosion protection	Standard: KN      Suitable for installation in industrial units, in water or power plants with a low pollutant concentration Option: Bronze      Suitable for use in seawater or saline atmospheres
Finish coating <sup>7)</sup>	Standard: Two-component iron-mica combination
Standard colour <sup>7)</sup>	silver-grey (DB 701, similar to RAL 9007)
Ambient temperature	Standard: – 25°C to + 80°C



**When exceeding the max. input torques, e.g. when using extensions on handwheels or cranks, the end stop or the valve may be damaged.**

- 1) Conversion factor from output torque to input torque to determine the gearbox size
- 2) at max. output torque
- 3) with adapter flange and price adder, possibly requires an extended coupling
- 4) without coupling, without operating element
- 5) IP 67 means: Protection against short-time immersion into water; max. 1 m head of water for the duration of 30 min. Note: For sea water or similarly aggressive media, please consult us
- 6) IP 68 means: Protection against submersion up to max. 6 m head of water for the duration of 72 hours, up to 10 operations during the submersion.
- 7) No painting required if a bronze housing is used

Lifetime	<b>Type</b>	<b>Lifetime (cycles OPEN - CLOSE - OPEN) for swing angle movements of 90° and a temperature range of  – 25°C to +80°C</b>
	GHE 05.1	1,000
	GHE 07.1	1,000
	GHE 10.1	1,000
	GHE 12.1	1,000
<b>Other information</b>		
Reference documents	Product description Part-turn gearboxes GHE 05.1 – GHE 12.1 Dimensions GHE 05.1 – GHE 12.1 Operation instructions GHE 05.1 – GHE 12.1	

## 4. Transport, storage and packaging

### 4.1 Transport

- Transport to place of installation in sturdy packing.
- Do not attach ropes or hooks to the operating element for the purpose of lifting by hoist.
- If the part-turn gearbox is mounted on valve, attach ropes or hooks for the purpose of lifting by hoist to valve and not to part-turn gearbox.

### 4.2 Storage

- Store in well-ventilated, dry room.
- Protect against floor dampness by storage on a shelf or on a wooden pallet.
- Cover to protect against dust and dirt.
- Apply suitable corrosion protection agent to bright surfaces.

If part-turn gearboxes are to be stored for a long time (more than 6 months), the following points must be observed additionally:

- Prior to storage: Protect bright surfaces, in particular the output drive parts and mounting surface, with long-term corrosion protection agent.
- Check for corrosion approximately every 6 months. If first signs of corrosion show, apply new corrosion protection.

### 4.3 Packaging

Our products are protected by special packaging for the transport ex works. The packaging consists of environmentally friendly materials which can easily be separated and recycled.

For the disposal of the packaging material, we recommend recycling and collection centres.

We use the following packaging materials:

Wooden material boards (OSB)/ cardboard/ paper/ PE film

## 5. Mounting to valve

Mounting is most easily done with the valve shaft pointing vertically upward. But mounting is also possible in any other position. The part-turn gearboxes leave the factory in position CLOSED.

- For **butterfly valves**, the mounting position is end position CLOSED. (Prior to mounting, the mechanical end stop CLOSED must be checked by turning the handwheel/ crank clockwise)
- For **ball valves**, the mounting position is end position OPEN. (Prior to mounting, bring the part-turn gearbox to the mechanical end stop OPEN by turning the handwheel/ crank counterclockwise)
- Thoroughly degrease mounting faces of part-turn gearbox and valve.
- Place coupling sleeve on to valve shaft and secure (figure A, detail A or B). Ensure that dimensions X, Y and Z are observed.

Figure C

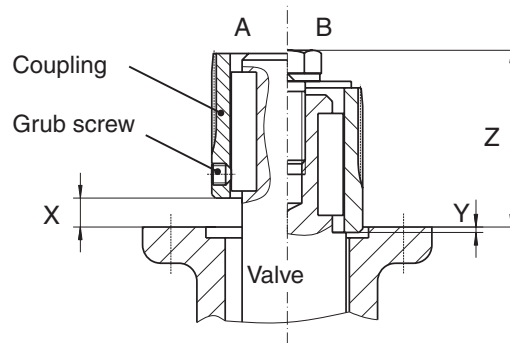

	GHE 05.1	GHE 07.1	GHE 10.1	GHE 12.1
X max. (mm)	2.5	2.5	3.5	5.5
Y max. (mm)	6	6	10	10
Z max. (mm)	36	35	47	59

- Apply non-acidic grease at tothing of coupling.
- Fit part-turn gearbox so that fixing holes in gearbox and valve mounting flange are in alignment. If necessary, move gearbox up or down one tooth on the coupling. If required, turn handwheel/ crank a little in direction OPEN or CLOSE until holes align to the threads.
- Ensure that the spigot mates uniformly in the recess and that the mounting faces are in complete contact.
- Fasten gearbox with bolts. Tighten bolts crosswise with torque wrench (torques see table).

Fastening torques				
Recommended strength class	A2-80 (reach of a screw: 1.5 x thread Ø)			
	M 6	M 8	M 10	M 12
Fastening torques (Nm)	10	24	48	82

## 6. Checking of the mechanical end positions CLOSED and OPEN

This check can only be performed on valves which are not yet mounted into a pipeline.

### 6.1 End position CLOSED

- Check whether mechanical end position of the valve corresponds to the mechanical end stop of gearbox by turning at operating element (clockwise for end position CLOSED).

If setting is required:

- Remove mechanical position indicator (bolt (03), figure B).
- Push down spring-loaded shaft (5) to stop with Phillipshead screwdriver and hold it depressed. While holding, set end stop by turning the input shaft.

Turning clockwise: Direction OPEN

Turning counterclockwise: Direction CLOSE



**Ensure that shaft (5) of the position indicator snaps up again after the adjustment.**

- Fit and adjust position indicator.  
Pointer is crosswise to the pipeline: Valve is closed  
Pointer is in line with the pipeline: Valve is open
- Fasten bolts (03) and secure with threadlocking adhesive.

**Figure B: Part-turn gearbox**

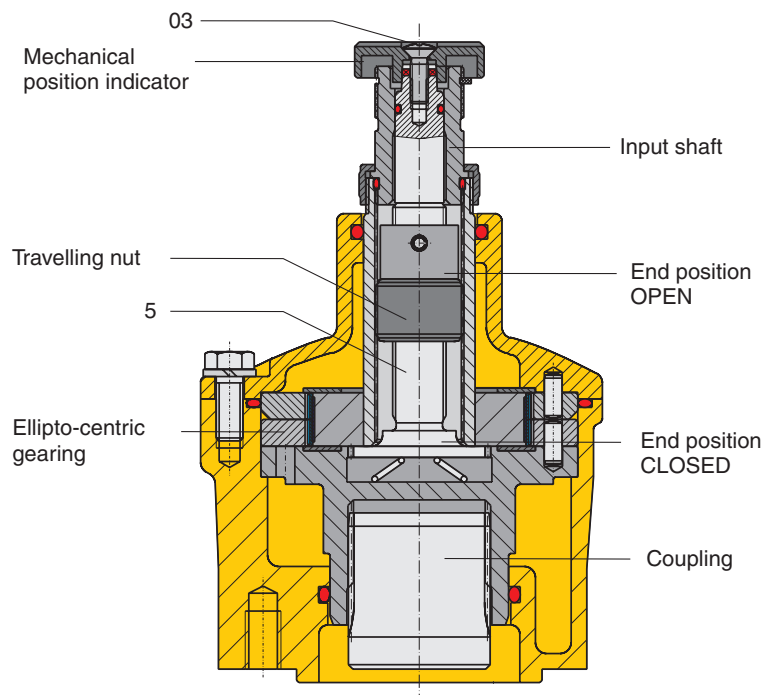

### 6.2 End position OPEN

The swing angle has been set in the factory (if not ordered otherwise) to approx. 90° and does not require readjustment.



## 7. Maintenance

For gearboxes with housing made of spheroidal cast iron, check for damage to paint finish after commissioning. Do a thorough touch-up to prevent corrosion. Original paint in small quantities can be supplied by AUMA.

AUMA part-turn gearboxes GHE require very little maintenance. Precondition for reliable service is correct commissioning.

The gear housing is filled with lubricant in the factory. This filling lasts for the whole lifetime.

Seals made of elastomers are subject to ageing and must therefore regularly be checked and, if necessary, be exchanged.

The described gearboxes are high-precision mechanical devices. Defective part-turn gearboxes can therefore only be repaired in the factory or in an authorised workshop.

## Notes

**Index****C**

Corrosion protection	6
Coupling	7

**E**

End positions CLOSED and OPEN	8
----------------------------------	---

**I**

Internet	11
----------	----

**M**

Maintenance	3,9
Mounting to valve	7

**P**

Packaging	6
-----------	---

**R**

Range of application	3
----------------------	---

**S**

Safety instructions	3
Storage	6

**T**

Technical data	4
Transport	6

**Information also available  
on the Internet:**

Inspection records and further gearbox information can be downloaded directly from the Internet by entering the order no. or comm. no. (refer to name plate).  
Our website: <http://www.auma.com>

# auma®

## Solutions for a world in motion

### Europe

#### AUMA Riester GmbH & Co. KG

Factory Müllheim  
**DE-79373 Müllheim**  
Tel +49 7631 809 - 0  
riester@auma.com  
www.auma.com

Factory Ostfildern-Nellingen  
**DE-73747 Ostfildern**  
Tel +49 711 34803 - 0  
riester@wof.auma.com

Service Centre Cologne  
**DE-50858 Köln**  
Tel +49 2234 2037 - 9000  
Service@sck.auma.com

Service Centre Magdeburg  
**DE-39167 Niederdodeleben**  
Tel +49 39204 759 - 0  
Service@scm.auma.com

AUMA Armaturentriebe GmbH  
**AT-2512 Tribuswinkel**  
Tel +43 2252 82540  
office@auma.at  
www.auma.at

AUMA (Schweiz) AG  
**CH-8965 Berikon**  
Tel +41 566 400945  
RettichP.ch@auma.com

AUMA Servopohony spol. s r.o.  
**CZ-10200 Praha 10**  
Tel +420 272 700056  
auma-s@auma.cz  
www.auma.cz

OY AUMATOR AB  
**FI-02270 Espoo**  
Tel +35 895 84022  
auma@aumator.fi

AUMA France S.A.R.L.  
**FR-95157 Taverny Cédex**  
Tel +33 1 39327272  
stephanie.vatin@auma.fr  
www.auma.fr

AUMA ACTUATORS Ltd.  
**GB- Clevedon North Somerset BS21 6QH**  
Tel +44 1275 871141  
mail@auma.co.uk  
www.auma.co.uk

AUMA ITALIANA S.r.l. a socio unico  
**IT-20023 Cerro Maggiore (MI)**  
Tel +39 0331 51351  
info@auma.it  
www.auma.it

AUMA BENELUX B.V.  
**NL-2314 XT Leiden**  
Tel +31 71 581 40 40  
office@benelux.auma.com  
www.auma.nl

AUMA Polska Sp. z o.o.  
**PL-41-310 Dabrowa Górnicza**  
Tel +48 32 26156 68  
R.Ludzien@auma.com.pl  
www.auma.com.pl

OOO Priwody AUMA  
**RU-141400 Moscow region for mail:  
124365 Moscow a/ya 11**  
Tel +7 495 221 64 28  
aumarussia@auma.ru  
www.auma.ru

ERICHs ARMATUR AB  
**SE-20039 Malmö**  
Tel +46 40 311550  
info@erichsarmatur.se  
www.erichsarmatur.se

#### GRÖNBECH & SÖNNER A/S

**DK-2450 København SV**  
Tel +45 33 26 63 00  
GS@g-s.dk  
www.g-s.dk

IBEROPLAN S.A.  
**ES-28027 Madrid**  
Tel +34 91 3717130  
iberoplan@iberoplan.com

D. G. Bellos & Co. O.E.  
**GR-13671 Acharnai Athens**  
Tel +30 210 2409485  
info@dgbellos.gr

SIGURD SØRUM A. S.  
**NO-1301 Sandvika**  
Tel +47 67572600  
post@sigurd-sorum.no

INDUSTRA  
**PT-2710-297 Sintra**  
Tel +351 2 1910 95 00  
jpalhares@tyco-valves.com

MEGA Endüstri Kontrol Sistemleri Tic. Ltd. Sti.  
**TR-06460 Öveçler Ankara**  
Tel +90 312 472 62 70  
megaendustri@megaendustri.com.tr

CTS Control Limited Liability Company  
**UA-02099 Kiyiv**  
Tel +38 044 566-9971, -8427  
v.polyakov@cts.com.ua

### Africa

AUMA South Africa (Pty) Ltd.  
**ZA-1560 Springs**  
Tel +27 11 3632880  
aumasa@mweb.co.za

A.T.E.C.  
**EG- Cairo**  
Tel +20 2 3599680 - 3590861  
atec@intouch.com

### America

AUMA ACTUATORS INC.  
**US-PA 15317 Canonsburg**  
Tel +1 724-743-AUMA (2862)  
mailbox@auma-usa.com  
www.auma-usa.com

AUMA Chile Representative Office  
**CL- Buin**  
Tel +56 2 821 4108  
aumachile@adsl.tie.cl

LOOP S. A.  
**AR-C1140ABP Buenos Aires**  
Tel +54 11 4307 2141  
contacto@loopsa.com.ar

Asvotec Termoindustrial Ltda.  
**BR-13190-000 Monte Mor/ SP.**  
Tel +55 19 3879 8735  
atuador.auma@asvotec.com.br

TROY-ONTOR Inc.  
**CA-L4N 5E9 Barrie Ontario**  
Tel +1 705 721-8246  
troy-ontor@troy-ontor.ca

MAN Ferrostaal de Colombia Ltda.  
**CO- Bogotá D.C.**  
Tel +57 1 401 1300  
dorian.hernandez@manferrostaal.com  
www.manferrostaal.com

PROCONTIC Procesos y Control Automático  
**EC- Quito**  
Tel +593 2 292 0431  
info@procontic.com.ec

IESS DE MEXICO S. A. de C. V.  
**MX-C.P. 02900 Mexico D.F.**  
Tel +52 55 55 561 701  
informes@iess.com.mx

#### Corsusa S.A.C.

**PE- Miraflores - Lima**  
Tel +511444-1200 / 0044 / 2321  
corsusa@corsusa.com  
www.corsusa.com

PASSCO Inc.  
**PR-00936-4153 San Juan**  
Tel +18 09 78 77 20 87 85  
Passco@prtc.net

Suplibarca  
**VE- Maracaibo Estado, Zulia**  
Tel +58 261 7 555 667  
suplibarca@intercable.net.ve

### Asia

AUMA Actuators (Tianjin) Co., Ltd.  
**CN-300457 Tianjin**  
Tel +86 22 6625 1310  
mailbox@auma-china.com  
www.auma-china.com

AUMA (INDIA) PRIVATE LIMITED  
**IN-560 058 Bangalore**  
Tel +91 80 2839 4655  
info@auma.co.in  
www.auma.co.in

AUMA JAPAN Co., Ltd.  
**JP-210-0848 Kawasaki-ku, Kawasaki-shi  
Kanagawa**  
Tel +81 44 329 1061  
mailbox@auma.co.jp

AUMA ACTUATORS (Singapore) Pte Ltd.  
**SG-569551 Singapore**  
Tel +65 6 4818750  
sales@auma.com.sg  
www.auma.com.sg

Al Ayman Industrial. Eqpts  
**AE- Dubai**  
Tel +971 4 3682720  
auma@emirates.net.ae

PERFECT CONTROLS Ltd.  
**HK- Tsuen Wan, Kowloon**  
Tel +852 2493 7726  
joeip@perfectcontrols.com.hk

DW Controls Co., Ltd.  
**KR-153-803 Seoul Korea**  
Tel +82 2 2113 1100  
sichoi@actuatorbank.com  
www.actuatorbank.com

AL-ARFAJ Eng. Company W. L. L.  
**KW-22004 Salmiyah**  
Tel +965 4817448  
arfaj@qualitynet.net

Petrogulf W.L.L.  
**QA- Doha**  
Tel +974 4350 151  
pgulf@qatar.net.qa

Sunny Valves and Intertrade Corp. Ltd.  
**TH-10120 Yannawa Bangkok**  
Tel +66 2 2400656  
sunnyvalves@inet.co.th  
www.sunnyvalves.co.th/

Top Advance Enterprises Ltd.  
**TW- Jhonghe City Taipei Hsien (235)**  
Tel +886 2 2225 1718  
support@auma-taiwan.com.tw  
www.auma-taiwan.com.tw

**Australia**  
BARRON GJM Pty. Ltd.  
**AU-NSW 1570 Artarmon**  
Tel +61 294361088  
info@barron.com.au  
www.barron.com.au

2006-08-18

# auma® auma®

AUMA Riester GmbH & Co. KG  
P.O. Box 1362  
79373 Müllheim, Germany  
Tel +49 7631 - 809-0  
Fax +49 7631 - 809 1250  
riester@auma.com  
www.auma.com

AUMA Riester GmbH & Co. KG  
P. O. Box 1151  
D - 73747 Ostfildern  
Tel +49 711 - 34803 0  
Fax +49 711 - 34803 34  
riester@wof.auma.com  
www.auma.com



Certificate Registration No.  
12 100/104 4269

For detailed information on the AUMA products refer to the Internet:

[www.auma.com](http://www.auma.com)

Y001.021/003/en/1.05